



SAAB

**BRINGING YOU
THE FUTURE OF
AEROSTRUCTURES**

SOME USE INNOVATIVE TECHNOLOGY OTHERS CREATE IT

We build aerostructures that are safe, efficient and reliable, that constantly break new ground, and always raise the bar for design and engineering. Our determination to be the best has kept us at the forefront of the industry for over 70 years, and there are plenty of boundaries left to push. You could say innovation is in our DNA.

Our experience, know-how and expertise are built on a history of developing and manufacturing complete aircraft. Since the foundation of Saab in 1937, thousands of aircraft have left our hangars, including the Saab 340, the Saab 2000 and Gripen – the world's first new-generation fighter in operation.

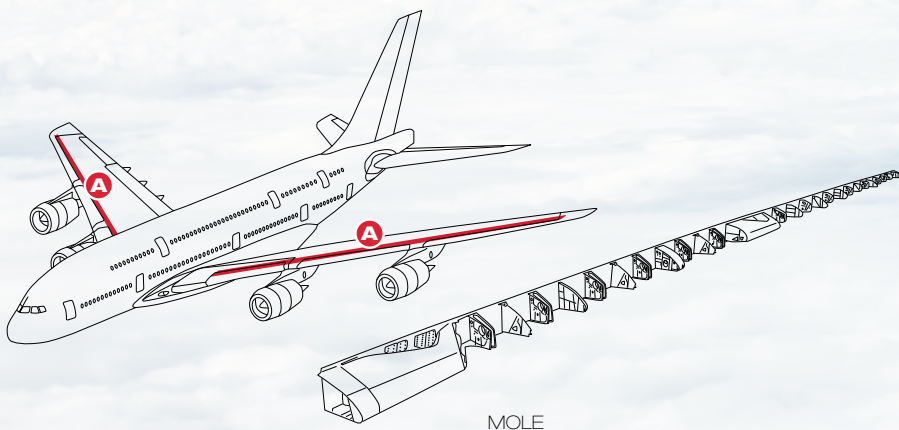

THINKING BIG

Saab produces MOLEs (Mid and Outer Fixed Leading-Edges) for the world's largest commercial aircraft – the Airbus A380. Each MOLE is 32 metres long and exceeding two tonnes. It is the single largest part ever produced by Saab.



1



CREW ESCAPE DOOR

2



LARGE CARGO DOOR

3

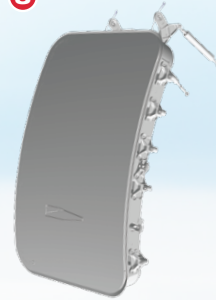

BULK CARGO DOOR

EFFICIENT INSTALLATION

Saab supplies the large and bulk cargo doors, as well as the crew escape doors for the Boeing 787 Dreamliner. A range of systems are built into the doors' composite structures, providing the customer with a lightweight door that is easy to install.

Today, our knowledge, expertise and global reach translate into state-of-the-art aerostructures that are cost-efficient, robust and safe.

In 1997, Saab made the decision to focus its commercial aeronautics business on supplying structural components to major aircraft manufacturers. We've established close working relationships with our customers, who see us as a key collaborator in the development of their aircraft.

As a tier-1 partner of Boeing and Airbus, we focus on developing wing structures, movables and doors. We use our knowledge and experience to strive for further improvements, so that we can offer an even better product to our customers.

LOW MAINTENANCE PARTNER

After decades of building entire aircraft from nose to tail, we've learnt a thing or two about aerostructures. We've perfected the art of developing, building and delivering structures that hit the

mark for our customers, while meeting the highest possible standards. Over this time, we have also fine-tuned our unique way of working.

COMMITTED AND **PROACTIVE**

In every project, challenges arise. Our aim is to find solutions before these challenges become problems for customers.

This proactive approach is at the heart of who we are, and it's what makes our customers feel secure when working with us.

AIRBUS A350
XWB-1000

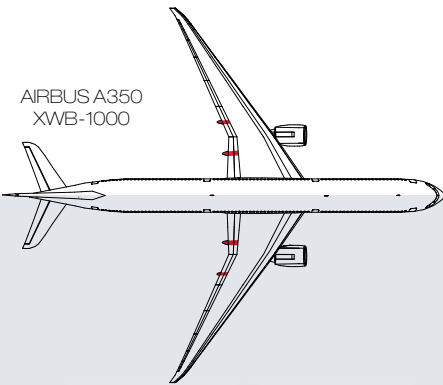

LEADING EDGE CAPABILITIES

Saab designs, develops and produces the attachment structure for the landing flaps on the A350 XWB-1000 – the largest aircraft in the A350 family. The landing flaps are attached to the wing's trailing edge, and are extended at low speeds, i.e. during take-off and landing.

AIRBUS A320

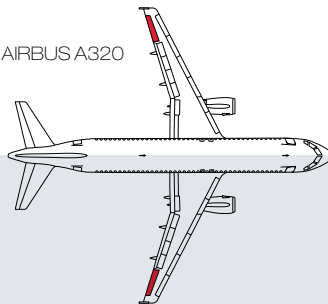

DRIVING EFFICIENCY

Saab is responsible for developing and producing ailerons for the Airbus A320 family. Always striving to improve our solutions, we redesigned the aileron in 2006. The new version requires half the number of components, and has significantly reduced production time and costs.



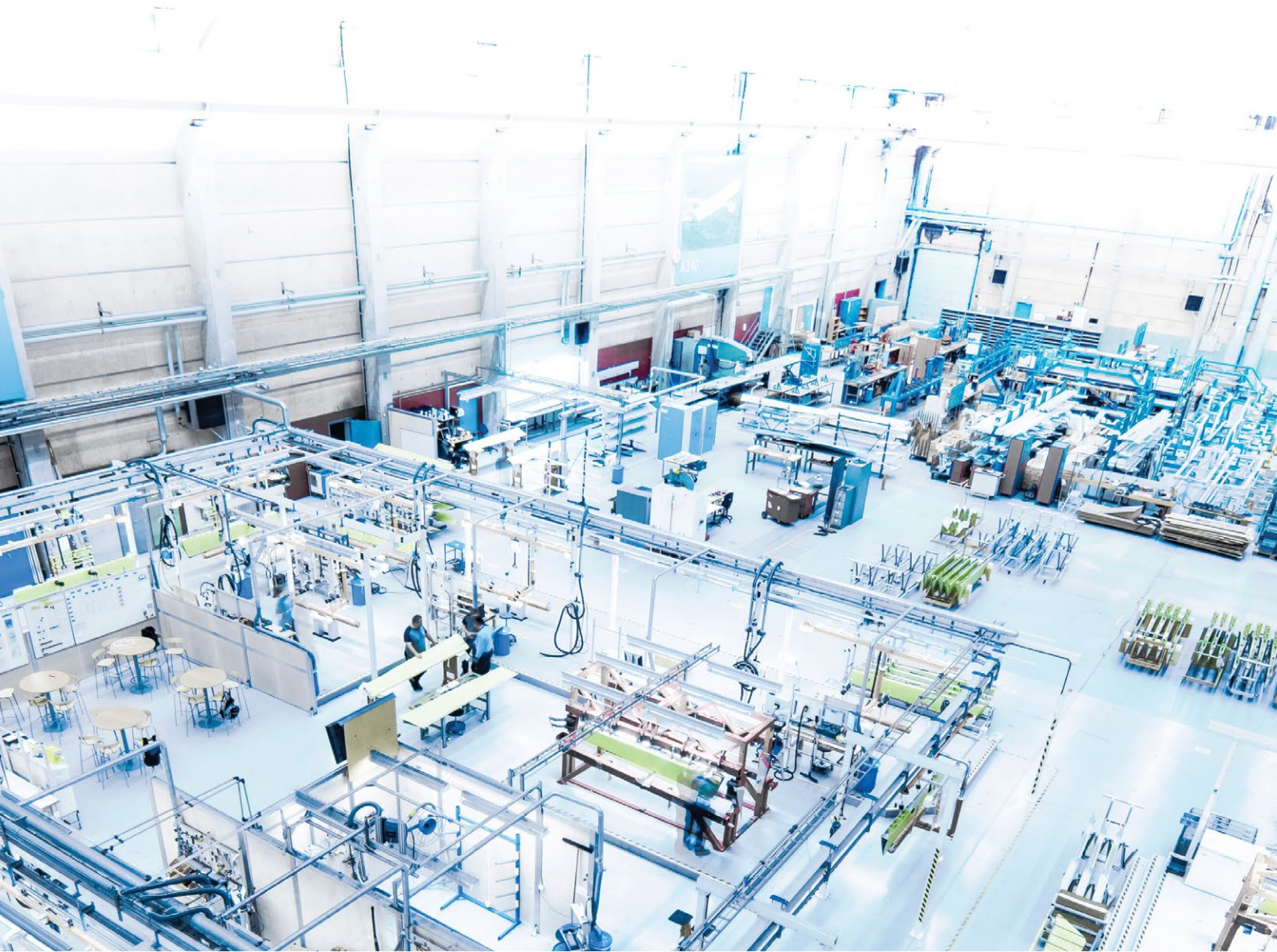

LEAN PRINCIPLES

We believe in efficient processes and added value at every stage – from the first concept to the final delivery. Using Lean principles helps us to deliver aerostructures on time and on budget, while our highly automated production lines ensure quality is consistently achieved in every part of the process.

By thinking, acting and working Lean, we're able to reduce unnecessary processes, increase our capacity, and limit waste. A Lean approach also means fewer production stages, which helps to improve the overall quality of our products. Another key benefit is the reduction of lead time for in-process alterations and delivery.



A PARTNER FOR THE **FUTURE**

THE INTEGRATOR

Saab has a long track record of being a partner to the major players in the aerospace market. This includes our work in risk-sharing on many programmes with Airbus and Boeing. We transfer our integration knowledge to all project partners and sub-contractors. This ensures that they understand and implement all customer requirements relating to systems and structures.

Our focus is on meeting the needs of our customers through ongoing development and an unrelenting dedication to excellence.

We're committed to collaboration and building strong foundations for the design, development and production of the next generation of aircraft components.

The nature of these collaborations means that individual work packages are often quite large in scope and the demands on partners can be heavy. We offer both technical and project management expertise, so our customers know they will get real value out of the partnership.



KNOWLEDGE THROUGH ENGINEERING

Clean Sky is one of Europe's largest commercial aircraft research programmes. It aims to reduce carbon dioxide, nitrogen oxides and noise emissions from European air traffic by between 20–40 percent by 2020.

As part of Clean Sky, Saab and its partners are developing a new wing with laminar flow properties that will reduce drag, and thereby fuel consumption and emissions. This work will provide the basis for the aircraft wings of the future.



ADVANCED KNOWLEDGE INTEGRATED SOLUTIONS

Through our established working relationships with key partners we're able to investigate new concepts, and then bring them to market much quicker than was previously possible.

The use of composite materials in aircraft is just one of the areas we're investigating. We have advanced knowledge of integrated composite structures and are researching ways to incorporate them into aerostructures. This could help reduce the overall cost of an aircraft by as much as 25 percent.

Cost is of course an important issue, and it's something we never lose sight of. We combine technical expertise with a wider business perspective, resulting in a very competitive solution for our customers.



OUR **INTEGRATIVE
APPROACH** SIGNIFICANTLY
REDUCES MAN HOURS

SUPPORT EVERY STEP OF THE WAY

At Saab, we manage the entire supply chain. We work openly with customers and support them in making critical decisions throughout the entire lifecycle of a project. Our holistic approach to the supply chain means our customers get a cost efficient solution.

As a technological leader, we carry out product development in close cooperation with suppliers and customers all over the world.

Our engineers use model-based design, which utilises electronic product models. This allows us to conduct various types of analysis of a product, including stress and aerodynamic testing, and off-the-market support.

There are many benefits to this approach for our customers and suppliers. Model-based design provides a common framework for communicating with customers and partners throughout the design process. At the same time, it supports the development cycle in the most efficient way – reducing required man hours significantly.



A DRIVER FOR **CHANGE**

COMPOSING COMPOSITES

In recent years we have increased our investment in composites research and development. Our team of experts has been exploring innovative design solutions, prototype methodologies, new tooling concepts and assembly ideas. The knowledge gained from our research has been implemented in a number of real-world solutions for our partners and customers.

For example, our work includes the composite cargo door for the Boeing 787 Dreamliner, tooling concepts for the Neuron UAV's composite panels, conceptual design and manufacturing of the A320 Aileron integrated composite box, and the highly integrated sub-scale wing box for the EU ALCAS programme.

With rapid prototyping and development, we push boundaries even further, improving knowledge of aerostructure composites and bringing the most efficient thinking to market.

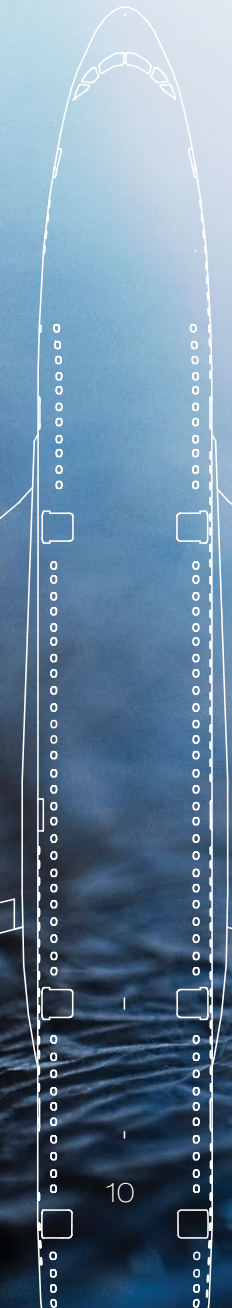

A TRULY **GLOBAL REACH**

Investing in existing and potential partnerships is another way we are preparing ourselves for the future. Work packages are growing in size, placing higher demands on our partners. We are committed to combining our strengths to meet customer needs.

Through our global supply chain, we have formed strategic partnerships with a number of countries, which gives customers direct access, and reduces risk.

Saab, together with Aequs, has a factory in Belgaum, India for aerostructure assemblies, called Aerostructures Assemblies India. The company assembles parts for commercial aircraft sub-structures.

This is a long-term commitment in a market that is strategically important for Saab and will strengthen our established position as a global player in the commercial aerostructures market.





SAAB

SAAB IS YOUR PARTNER FOR
ADVANCED AEROSTRUCTURES,
BRINGING YOU **INNOVATION AND**
EXPERTISE IN COMPOSITE AND
ASSEMBLY SOLUTIONS.

www.saabgroup.com