



SAAB



FIBER OPTIC GYRO UNIT 8088 009-506 THREE-AXIS

The digital output alternative. Based on our Fiber Optic technology backed up by over 40-years experience in inertial sensors.



Fiber Optic Gyro (FOG).

This family of Gyro Units is specifically designed for stabilization applications where there is a need for digital output.

They offer a very attractive solution based on fiber optic gyro technology that gives a number of benefits.

As sensors three Saab manufactured single axis Fiber Optic Gyros with built-in temperature sensors are used.

The units also include DC/DC converters and filters to comply with international standards of EMI requirements and digital processing circuitry to give digital output capability.

If required the units could be delivered in single-axis or dual-axis configuration.

Applications:

- Gun and turret stabilization
- Sight stabilization
- Antenna stabilization

Features:

- RS-232, RS-422
- Solid state design
- Wide bandwidth
- High shock survivability
- Very good bias stability
- Short start-up time

Optional feature:

- Compensated analog output

Company Background

Saab has been a producer of gyros of various designs for over 40 years. Production was initially intended for Saab designed aircraft sight and missile requirements.

Since the end of 70's the gyro production have expanded into a product line of it's own including design and production of gyro products for worldwide customers. Up to the present time we have produced more than 40.000 sensors. Gyros based on FOG technology has been the main product since the end of 90's.



Mechanical Gyros.



DIMENSIONAL DRAWING FOG UNIT 8088 009-506

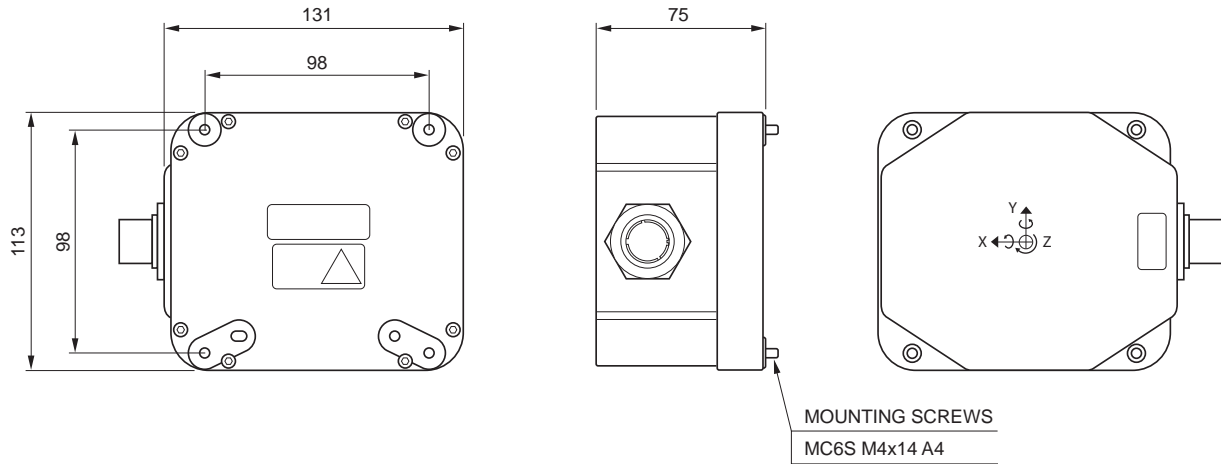

SPECIFICATION VERSION 8088 009-506

CHARACTERISTICS	UNIT	VALUE
Range	°/s	±150
Bias Over Temperature Range	°/h max	50
Bias stability 1	°/h max	10
Scale Factor @ ±75°/s	°/sec/bit	1.834*10 ⁻⁵
SF error Over Temperature Range	%	±0.3
Non-Linearity ±150°/s	% of Full Scale max	±0.2
Bandwidth	Hz min	100
Start up time	s max	1
Axis misalignment	mrad max	5
Input voltage	VDC	+18 – +32
Input current at 28 VDC	mA max	500

DIGITAL OUTPUT FORMAT

RS-232	24 bits resolution
RS-422	24 bits resolution

ENVIRONMENTS

Shock	g: msec	300 : 1
Vibration, sine	g : Hz	10 : 20-2000
Vibration, random	g ² /Hz : Hz	0.09 : 20-2000
Operating temperature range	°C	-30 – +60
Storage temperature range	°C	-40 – +75